

Panel Specifications

1.1 Power supply

Transformer Input: 16.5 VAC or 40VA (Models 320 or 321) or 100VA (Model 322).

Standby Battery: 12 VDC 6.5Ah (40VA charges two batteries, 100VA charges three or four batteries))

Auxiliary Output: 12 VDC at 600mA with 40VA transformer

Bell Output: 12 VDC at 1 Amp

Inherent Power Limited

1.2 Communication

Built in Dialer communication to DMP Model SCS-1 Receivers

Built in Multiplex communication to DMP Model SCS-1 Receivers

Built in DDMX communication to DMP Model SCS-1 Receivers

Built in CID communication to non-DMP receivers

Optional Model 893 Dual Phone Line Module with phone line supervision

Can operate as a local system

1.3 Panel loops

Four 1K Ω EOL burglary loops (loops 1 to 4)

One 3.3K Ω EOL Class B powered loop with reset (loop 5)

1.4 Keypads and expanders

You can connect up to eight of the following keypads or expanders to the 1912XR keypad data bus:

- 670, 770, or 771 Alphanumeric Keypads
- 711, 714, and 715 Loop Expanders
- 5845LX Glassbreak single point detector
- 6155LX PIR single point detector

You can connect the following devices to the LX-Bus of the Model 862N, 862P, 872, and 881 Interface Cards up to the maximum number of addresses. Also see Accessory Devices in section 4.1.

- 714 and 715 Loop Expanders - up to 25 devices
- 716 Output Expander - up to 25 devices
- 5845LX Glassbreak single point detector - up to 100 devices
- 6155LX PIR single point detector - up to 100 devices

The 714 and 715 Loop Expanders each provide four loops.

The 716 Output Expander provides four Form C relays (SPDT) and four 50mA switched grounds (open collector) suitable for a variety of annunciation and control applications.

1.5 Output contacts

Two on-board auxiliary Form C outputs. See section 13.1. You can have up to 100 additional outputs when using 716 Output Expanders and an 862N, 862P, 872, or 881 Interface Card.

Outputs require two Model 305 relays, each rated for 1 Amp at 30 VDC or 0.5 Amp at 120 VAC

The panel also provides four auxiliary voltage outputs rated for 50mA at 12 VDC. See section 14.1.

1.6 Enclosure specifications

The 1912XR is shipped installed in its enclosure with end of line resistors, battery leads, and programming sheets.

Size:	12.5" x 11.5" x 3.0"
Weight:	6 lbs
Color:	Black (61) or Grey (63)
Construction:	18 gauge cold rolled steel

Introduction

2.1 Description

The DMP 1912XR Command Processor is a powerful 12 VDC, combined burglary and fire communicator panel with battery backup. The 1912XR provides four on-board burglary loops and one on-board 12 VDC Class B powered fire loop. The fire loop has a reset capability to provide for 2-wire smoke detectors, relays, or other latching devices. The 1912XR can communicate to one or two DMP SCS-1 Receivers using digital dialer, Contact ID, multiplex, or a combined dialer/multiplex format.

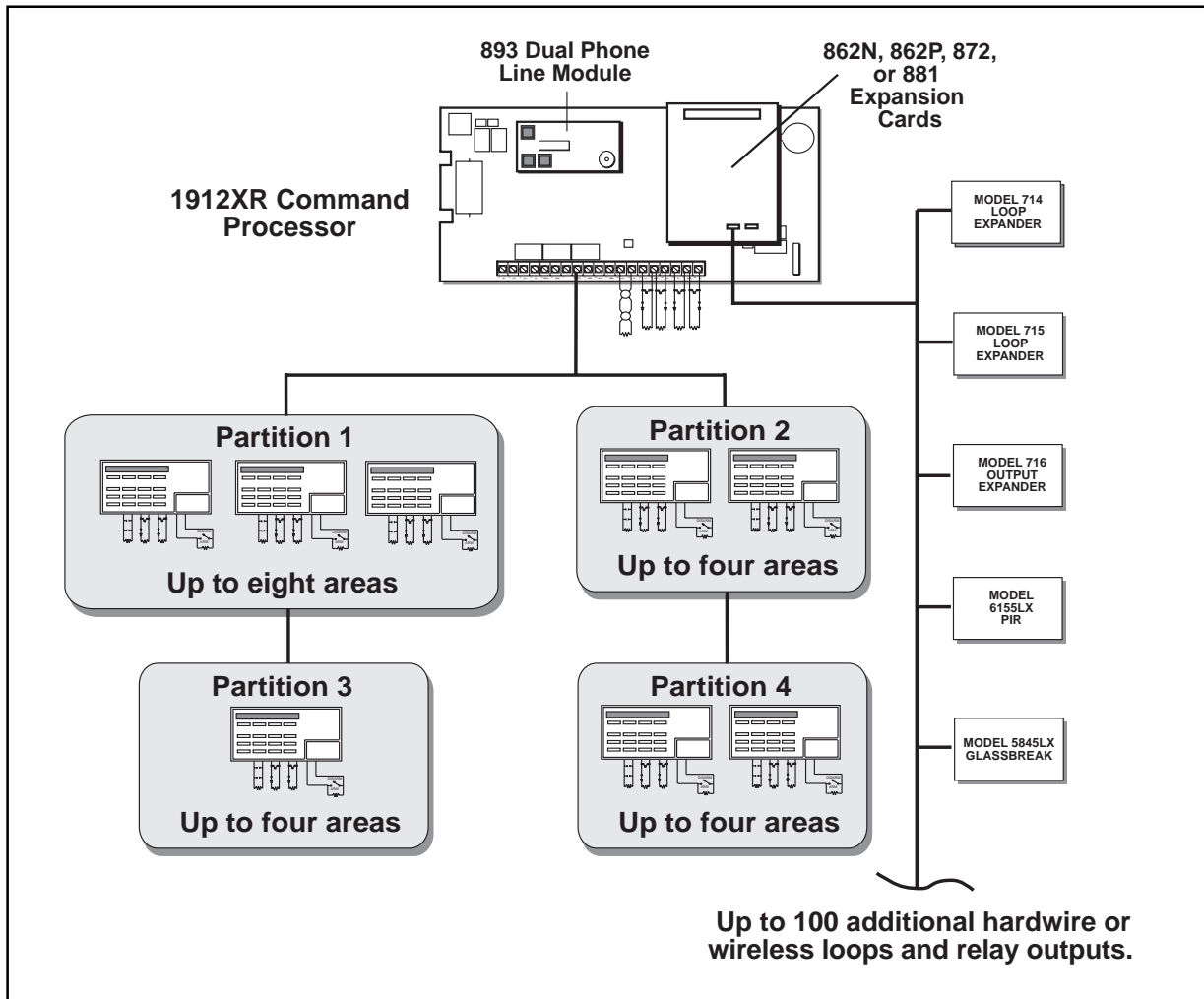

Figure 1: Typical 1912XR System Configuration

2.2 Expansion loops

Up to 132 additional loops are available on the 1912XR by using the loop expansion capability of DMP Security Command keypads and loop expander modules. The panel's keypad data bus supports up to eight device addresses with each device supporting up to four programmable expansion loops.

Up to 100 loops are available on the LX-Bus™ of a DMP 862N, 862P, 872, or 881 Interface Card using combinations of the following:

- 711 Single Point Loop Expander Module (up to 100)
- 714 or 715 Loop Expander Modules (up to 25)
- 6155LX PIRs or 5845LX Glassbreak Detectors (up to 100)

2.3 Partitions and areas

The 1912XR can be programmed into four separate partitions. Partition 1 can be expanded into eight separate reporting areas. Partitions 2 to 4 can each be expanded into four separate reporting areas. The 1912XR panel supports up to a total of 20 areas for all partitions combined.

2.4 Central station communication

You can program the 1912XR panel for local annunciation only or for reporting to remote DMP SCS-1 Receivers using digital dialer, Contact ID, multiplex, or the combined dialer/multiplex (DDMX) communication format. Using DDMX allows you to have digital dialer during disarmed periods and automatic multiplex connection after the last area in the system is armed. The 1912XR connects at the premises to a standard RJ31X or RJ38X telephone jack. Use the DMP 893 Dual Phone Line Module when connecting the 1912XR panel to two separate phone lines in fire or burglary applications.

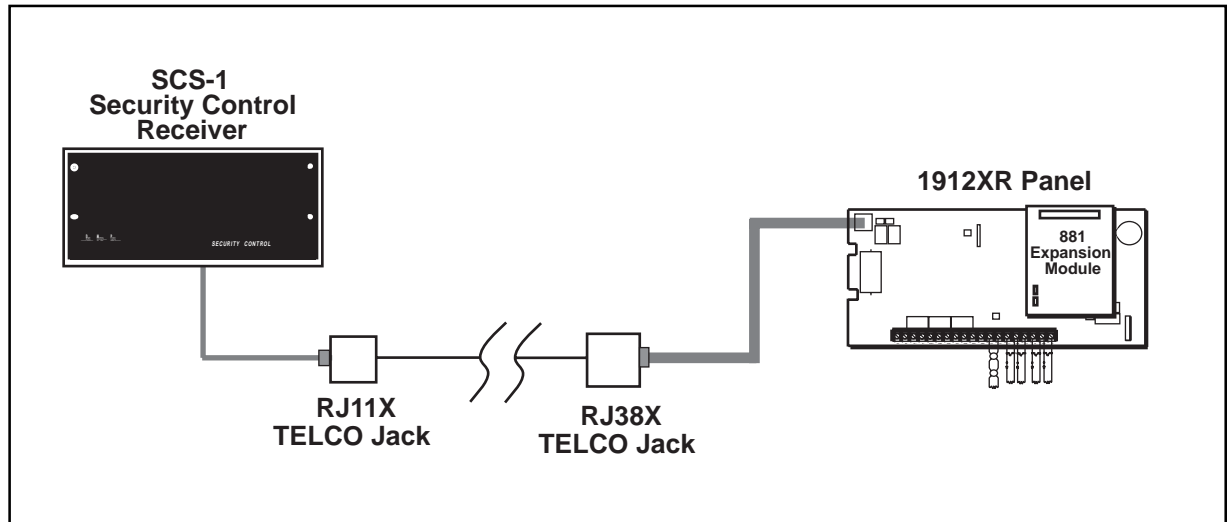

Figure 2: The 1912XR can use multiplex, digital dialer, CID, or DDMX communication

2.5 Before you begin

Before installing the 1912XR, we recommend you read through the entire contents of this guide. Familiarize yourself with the features of the panel and the key points to remember during the installation. Be sure to read and understand all of the caution statements printed in bold italics.

In addition to this installation guide, you should also read through and familiarize yourself with these other product documents:

- 1912XR Programming Manual (LT-0171)
- Security Command User's Guide (LT-0172)
- 1912XR Program Information Sheets (LT-0176)
- 714 Loop Expander Installation Sheet (LT-0161)
- 715 Loop Expander Installation Sheet (LT-0162)
- 862N and 862P Installation Sheet (LT-0202)
- 872 HARD-WIRE-LESS Installation Sheet (LT-0203)
- 881 Expansion Interface Installation Sheet (LT-0180)
- 5845LX Glassbreak Sensor Installation Sheet (LT-0219)
- 6155LX PIR Installation Sheet (LT-0211)

2.6 About this guide

The information contained in this guide is organized into four sections: Table of Contents, Introduction, Installation, and Troubleshooting.

- The Table of Contents at the front of this guide lists all of the headings and subheadings used throughout each section. To the right of each heading is the section number where the information can be found.
- The Introduction section gives you an overview of the various components that go into a 1912XR system and diagrams some typical system configurations. This section gives descriptions of the panel, keypads, loop expanders, and accessory modules and provides details on how each of them operate together in the system.
- The Installation section begins with mounting instructions for the enclosure and takes you through the proper way to power up the panel prior to programming.
- The Troubleshooting section includes some of the most common installation and service questions encountered by our technicians and should be helpful in making your installation or service call run smoothly.

Caution notes

Throughout this guide you'll see caution notes containing information you need to know when installing the 1912XR panel. These cautions are written with a bold, italicized introductory clause followed by a detailed description of the caution. See the example shown below:

Always ground the panel before applying power to any devices: The 1912XR must be properly grounded before connecting any devices or applying power to the panel. Proper grounding protects against Electrostatic Discharge (ESD) that can damage system components.

Whenever you see a caution note, make sure you completely read and understand its information. Failing to follow the caution note can cause damage to the equipment or improper operation of one or more components in the system.

2.7 How to use this guide

To locate information about the installation of the 1912XR, first go to the Table of Contents at the front of this guide. Find the subject heading that closely describes the information you need and turn to the section number shown to the right of the heading.

The text that follows the heading has been written to provide as much information about the subject as possible. If you can't find the information you need under that heading, try scanning through a few of the headings before and after and reading the text under those that sound similar.

System Components

3.1 Description

The DMP 1912XR system is made up of an alarm panel with built in communicator, an enclosure, and a 16.5 VAC transformer. You can add up to eight Security Command keypads, an expansion interface module, loop and output expanders, and initiating and indicating circuit modules. You can also connect auxiliary devices to the panel's output relays to expand the basic system. Combined current requirements of additional modules may require an auxiliary power supply. Refer to section 7.6 in this manual when calculating power requirements.

3.2 Wiring diagram

The 1912XR system below shows some of the accessory modules you can connect for use in various applications. A complete description of each module follows.

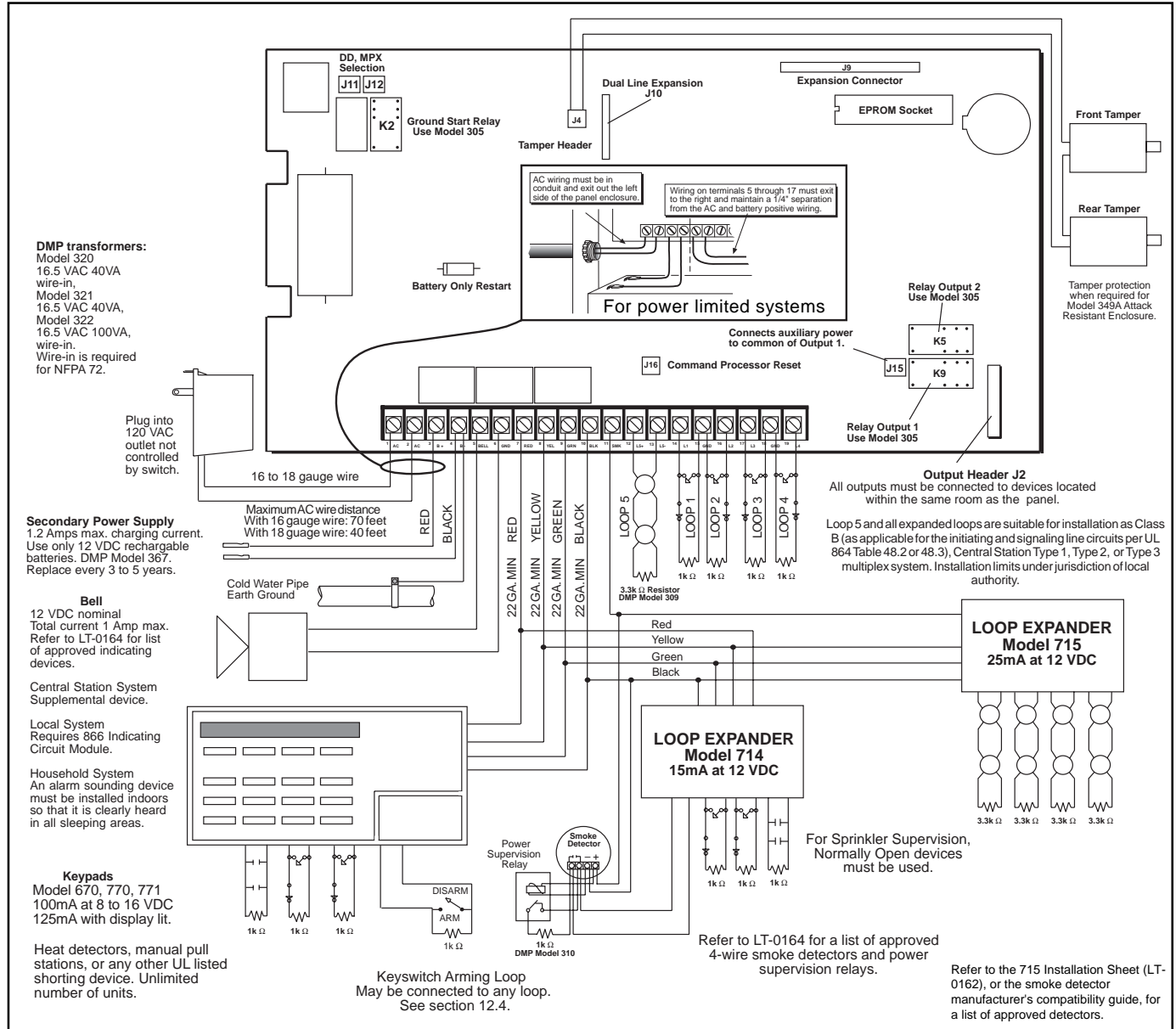

Figure 3: 1912XR wiring diagram

3.3 Lightning protection

Metal Oxide Varistors and Transient Voltage Suppressors help protect against voltage surges on input and output circuits of the 1912XR. Additional surge protection is available by installing the DMP 370 or 370RJ Lightning Suppressors.

Accessory Devices

4.1 Loop and output modules and interface cards

711 Single Point Loop Expander

The 711 module provides one Class B burglary loop for connecting burglary and non-powered fire devices.

714 Loop Expander

The 714 module provides four Class B burglary loops for connecting burglary and non-powered fire devices.

715 Loop Expander

The 715 module provides four 12 VDC Class B powered loops for connecting smoke detectors, glassbreak detectors, or other 2 or 4-wire devices.

716 Output Expansion Module

The 716 provides four Form C (SPDT) outputs and four loop following switched grounds (open collector). The 716 is addressed using rotary switches to match the panel's loop numbers.

717 Graphic Annunciator Module

The 717 provides 20 loop following switched grounds (open collector) for a variety of remote annunciation and control applications.

862N and 862P Interface Cards

Both cards provide an LX-Bus for connecting loop and output expansion modules. The 862N allows the 1912XR to communicate alarm and system information over existing computer data networks. The 862P allows you to connect a 40 or 80 character serial printer to the 1912XR panel for real time printing of system events.

872 HARD-WIRE-LESS™ Interface Card

The 872 card provides you with 100 loop addresses you can assign to either hardwire or wireless devices. A wireless receiver is required for using wireless devices.

881 Expansion Interface Card

The 881 card allows you to connect loop and output expander modules to the 1912XR panel to provide a maximum of 100 additional loops.

4.2 Indicating and initiating modules

865 Supervised Style Y or Z Indicating Module

The 865 provides up to 1 Amp of supervised alarm current when using the bell output of the 1912XR panel and up to 5 Amps at 12 or 24 VDC when using a listed auxiliary power supply. The 865 can supervise 2-wire Style Y or W circuits or 4-wire Style Z or X circuits for ground faults, opens, and shorts with individual LED annunciation.

866 Indicating Circuit Module

The 866 module provides up to 1 Amp of supervised alarm current using the bell output of the 1912XR panel and up to 5 Amps at 12 or 24 VDC when using a listed auxiliary power supply.

869 Dual Style D Initiating Module

The 869 provides two Style D, 4-wire initiating loops for connecting waterflow switches and other non-powered fire and burglary devices.

4.3 893 Dual Phone Line Module

The 893 allows you to connect and supervise two phone lines to the 1912XR panel. The 893 monitors the voltage of the phone line and reports trouble when the level drops below 3 VDC.

4.4 Security Command® keypads

You can connect up to eight Model 670, 770, or 771 Security Command keypads to the keypad data bus provided by the panel on terminals 7, 8, 9, and 10. Use an auxiliary power supply when connecting more than 5 keypads or when installing excessively long wire runs.

Installation

5.1 Mounting the enclosure

The metal enclosure for the 1912XR must be mounted in a secure, dry place to protect the panel from damage due to tampering or the elements. It is not necessary to remove the 1912XR PC board when installing the enclosure.

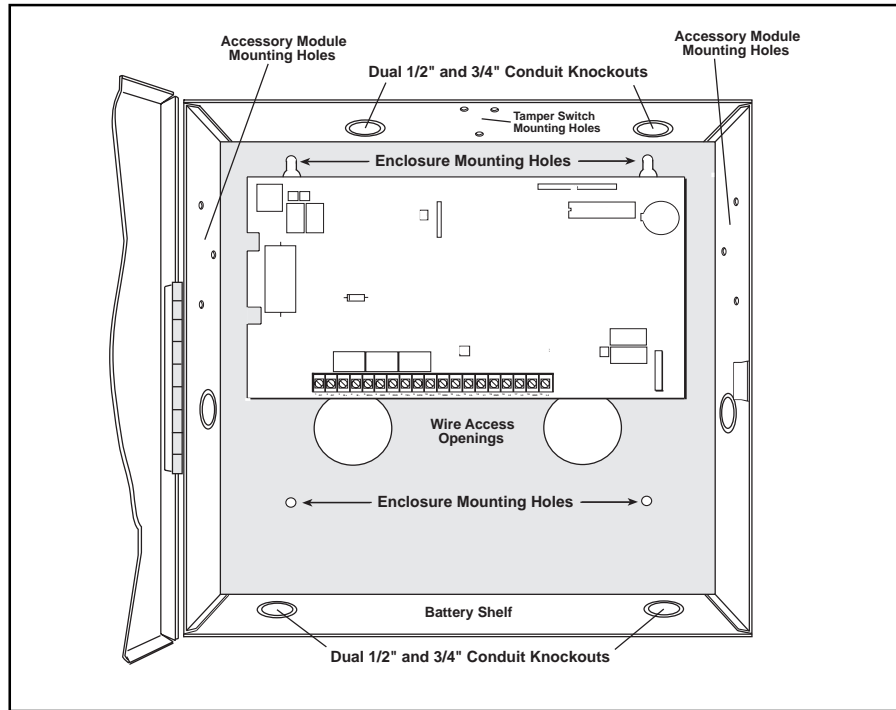

Figure 4: 1912XR in standard enclosure

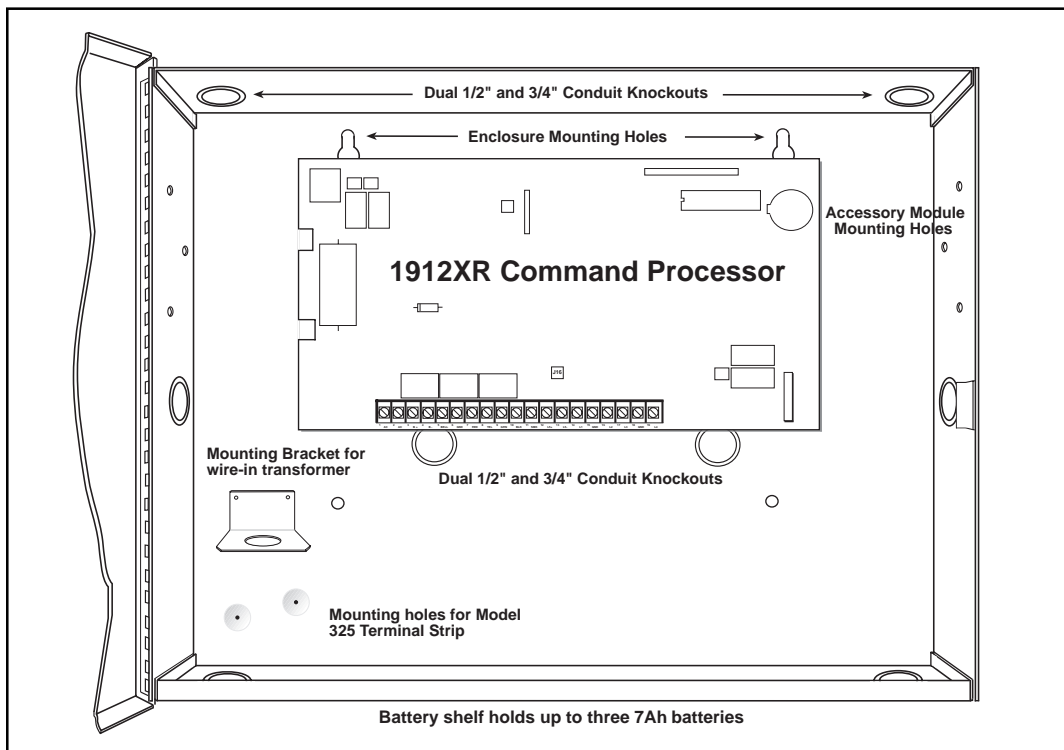

Figure 4A: 1912XR in Model 350 Large Enclosure

5.2 Mounting keypads and loop expanders

Security Command keypads have removable covers that allow you to easily mount the keypad to a wall or other flat surface using the screw holes provided on each corner of the base. Before mounting the base, connect the keypad wire harness leads to the keypad cable from the panel and to any device wiring run to that location. Then attach the harness connector to the pin connector on the PC board, mount the base, and install the keypad cover making sure all of the keys extend through their respective holes.

For mounting keypads on solid walls, or for applications where conduit is required, use a DMP 775, 776, or 778 keypad conduit backbox.

The DMP 711, 714, 715, and 716 expanders are contained in molded plastic housings with removable covers. The housing base contains the loop expander module and also provides you with mounting holes for installing the unit to a wall or other surface.

5.3 Connecting serial devices

Keypad data bus

The keypad data bus requires only a 4-wire cable between devices and the panel. You can connect devices in parallel on the same cable or provide separate runs back to the panel. The maximum cable length for one keypad can be up to 500 feet using 22 gauge wire or up to 1000 feet using 18 gauge wire. Additional keypads installed on the same cable decrease the maximum distance at which they'll operate properly.

Refer to the wiring diagram (section 3.2) in this guide for additional wiring information.

LX-Bus™ (Models 862N, 862P, 872, and 881 Interface Cards)

The LX-Bus provided on these cards also requires only a 4-wire cable between devices and the panel. You can connect devices together on the same cable with the total cable length for each run being determined by the number of devices and the gauge of wire being used.

Refer to the table below for determining wiring distances using 22 AWG and 18 AWG.

# of expansion devices	Distance when powered from panel		Distance when powered from auxiliary power supply *	
	22 AWG	18 AWG	22 AWG	18 AWG
1	3940'	9875'	7500'	9375'
2	2735'	6855'	7500'	9375'
3	1925'	4830'	7500'	9375'
4	1420'	3565'	7500'	9375'
5	1140'	2855'	7500'	9375'
6	900'	2250'	7500'	9375'
8	700'	1755'	7500'	9375'
10	550'	1370'	7500'	9375'
15	370'	930'	7500'	9375'
20	265'	660'	7500'	9375'
25	200'	495'	7500'	9375'

* Locate auxiliary power supply at the far end of the wire run.

Figure 5: Expansion device wiring distances

Note: This table is provided for convenience in determining approximate wiring distances and gauges only. Individual installations may vary and support greater or lesser distances due to environmental or other factors.

Primary Power Supply

6.1 AC terminals 1 and 2

Connect the transformer wires to terminals 1 and 2 on the panel. Use no more than 70 ft of 16 gauge, or 40 ft of 18 gauge, wire between the transformer and the 1912XR.

Always ground the panel before applying power to any devices: The 1912XR must be properly grounded before connecting any devices or applying power to the panel. Proper grounding protects against Electrostatic Discharge (ESD) that can damage system components. See Earth ground.

6.2 Transformer types

The standard transformer for the 1912XR is 16.5 VAC 40VA, which provides up to 600mA of auxiliary current. Refer to the 1912XR Wiring Diagram (LT-0182) on the panel enclosure door for a list of optional transformers. The total current available is limited by the total battery standby requirements.

The transformer must be connected to a 120 VAC 60 Hz commercial power outlet that is not controlled by a wall switch. **Never share the transformer output with any other equipment.**

The Model 320 or 322 wire-in transformers are required for NFPA 72 applications.

Secondary Power Supply

7.1 Battery terminals 3 and 4

Connect the black battery lead to terminal 4 on the panel and to the negative terminal of the battery. The negative terminal connects to the enclosure ground internally through the 1912XR circuit board. Connect the red battery lead to terminal 3 on the panel and to the positive terminal of the battery. **Observe polarity when connecting the battery.**

You can add a second battery in parallel using the DMP Model 318 Dual Battery Harness.

Use sealed lead-acid batteries only: Use the DMP Model 367, 12 VDC 6.5Ah sealed lead-acid rechargeable battery. Batteries supplied by DMP or manufactured by Eagle Picher or Yuasa have been tested to ensure proper charging with DMP products.

GEL CELL BATTERIES CANNOT BE USED WITH THE 1912XR PANEL.

7.2 Earth ground

Terminal 4 of the 1912XR panel must be connected to earth ground using 14 gauge or larger wire to provide proper transient suppression. DMP recommends connecting to a cold water pipe or ground rod only. Do not connect to electrical conduit or a telephone company ground.

7.3 Battery only restart

When powering up the 1912XR panel without AC power, it's necessary to short across the CR23 leads to pull in the battery cutoff relay. The leads need a momentary short only. Once the relay has pulled in, the battery voltage holds it in that condition. If the 1912XR panel is powered up with an AC transformer, the battery cutoff relay is pulled in automatically.

7.4 Replacement period

DMP recommends the battery be replaced every 3 to 5 years under normal use.

7.5 Discharge/recharge

The 1912XR battery charging circuit float charges at 13.9 VDC at a maximum current of 1.2 Amps using a 40VA transformer. The total current available is reduced by the combined auxiliary current draw from terminals 7, 11, and 12. The various battery voltage levels are listed below:

Battery Trouble:	Below	11.9 VDC
Battery Cutoff:	Below	10.2 VDC
Battery Restored:	Above	12.6 VDC

7.6 1912XR power requirements

During AC power failure, the 1912XR panel and all auxiliary devices connected to the 1912XR draw their power from the battery. All devices must be taken into consideration when calculating the battery standby capacity. Below is a list of the power requirements of the 1912XR panel. Add the additional current draw of Security Command keypads, loop expanders, smoke detector output, and any other auxiliary devices used in the system for the total current required. The total is then multiplied by the total number of standby hours required to arrive at the total ampere/hours required.

1912XR STANDBY BATTERY POWER CALCULATIONS

		Standby Current		Alarm Current
1912XR Command Processor Panel		130mA _____		130mA _____
Relay Outputs 1-2 (ON)	Qty _____ x	30mA _____	Qty _____ x	30mA _____
Voltage Outputs 3-6 (ON)	Qty _____ x	5mA _____	Qty _____ x	5mA _____
Active Loops 1-4	Qty _____ x	1.6mA _____	Qty _____ x	*2mA _____
Active Loop 5		4mA _____		30mA _____
2-Wire Smokes	Qty _____ x	.1mA _____	Qty _____ x	.1mA _____
893 Dual Phone Line Module		12mA _____		50mA _____
862N Network Card	Qty _____ x	15mA _____	Qty _____ x	15mA _____
862P Printer Card	Qty _____ x	15mA _____	Qty _____ x	15mA _____
872 HARD-WIRE-LESS™ Card	Qty _____ x	15mA _____	Qty _____ x	15mA _____
881 Expansion Card	Qty _____ x	15mA _____	Qty _____ x	15mA _____
				Bell Output 1000mA max. _____
670, 770, 771 Keypads	Qty _____ x	125mA _____	Qty _____ x	125mA _____
Annunciator (ON)			Qty _____ x	20mA _____
Active Loops	Qty _____ x	1.6mA _____	Qty _____ x	*2mA _____
714 Loop Expander	Qty _____ x	7mA _____	Qty _____ x	7mA _____
Active Loops (EOL installed)	Qty _____ x	1.6mA _____	Qty _____ x	*2mA _____
715 Loop Expander	Qty _____ x	7mA _____	Qty _____ x	7mA _____
Active Loops (EOL installed)	Qty _____ x	4mA _____	Qty _____ x	30mA _____
2-Wire Smokes	Qty _____ x	.1mA _____	Qty _____ x	.1mA _____
716 Output Expander	Qty _____ x	7mA _____	Qty _____ x	7mA _____
Active Form C Relays			Qty _____ x	28mA _____
Aux. Powered Devices on Terminals 7 (Other than 670, 770, 771, 714, 715, 716)		_____ mA		_____ mA
	Total Standby	_____ mA	Total Alarm	_____ mA

* Based on 10% of active loops in alarm condition

Total Standby _____ mA x number of standby hours needed _____ = _____ mA/hours

Total Alarm + _____ mA/hours

Total _____ mA/hours

x .001 _____

= _____ Ampere/Hours Required

Cannot exceed 6.5 with one 367 Battery
 Cannot exceed 13.0 with two 367 Batteries
 Cannot exceed 19.5 with three 367 Batteries
 Cannot exceed 26.0 with four 367 Batteries

Transformer required: Whenever there are three or four batteries being charged by the 1912XR panel, you must install the DMP Model 322 Transformer.

7.7 Battery supervision

The 1912XR tests the battery once every hour when AC power is present. The test is done at 15 minutes past the hour and lasts for five seconds. A load is placed on the battery and if its voltage falls below 11.9 VDC, a low battery is detected. If AC power has failed, a low battery is detected **any time** the battery voltage falls below 11.9 VDC.

If a low battery is detected with AC power present, the test is repeated every two minutes until the battery charges above 12.6 VDC; the battery restored voltage. If a faulty battery is replaced with a fully charged battery, the restored battery will not be detected until the next two minute test is done.

7.8 Battery cutoff

The panel disconnects the battery any time the voltage of the battery drops below 10.2 VDC. This prevents deep discharge damage to the battery.

Bell Output

8.1 Terminals 5 and 6

Nominal 12 VDC is supplied by terminal 5 on the panel to power alarm bells or horns. The output is rated for a maximum output of 1 Amp. This output can be steady or pulsed depending upon the Bell Action specified in Output Options. Terminal 6 is the ground reference for the bell circuit.

Keypad Data Bus

9.1 Description

Terminals 7, 8, 9, and 10 of the 1912XR panel are designated as the keypad data bus. You can connect any combination of Security Command keypads and loop expanders up to the maximum of eight devices.

9.2 Terminal 7 - RED

This is a positive 12 VDC for powering Security Command keypads and loop expanders on the keypad data bus. This is also where power for any auxiliary device is supplied. The ground reference for terminal 7 is terminal 10. The maximum output is rated at 600mA when using a 40VA transformer. The output current is shared with the smoke detector output on terminal 11 and Loop 5. The auxiliary output power can also be internally connected to the common terminal of relay output 1 by installing the J15 jumper. All auxiliary devices totalled together must not exceed the panel's maximum current rating.

Terminals 7 also provides power for devices used on 862N, 862P, 872, and 881 expansion cards.

9.3 Terminal 8 - YELLOW

Data receive from keypads and loop expanders. It cannot be used for any other purpose.

9.4 Terminal 9 - GREEN

Data transmit to keypads and loop expanders. It cannot be used for any other purpose.

9.5 Terminal 10 - BLACK

Terminal 10 is the ground reference for Security Command keypads, loop expanders, and any auxiliary devices being powered by terminals 7 or 11.

Smoke and Glassbreak Detector Output

10.1 Terminal 11

This is a positive 12 VDC for powering 4-wire smoke detectors or other powered devices. This output can be turned off by the user for 5 seconds using the Sensor Reset Menu Option to reset latched devices. Terminal 10 is the ground reference for terminal 11.

10.2 Current rating

The Output current from terminal 11 is shared with terminal 7 and terminal 12. The total current draw of all devices powered from the panel must be included with terminal 7 calculations and must not exceed the maximum output rating of 600mA.

Powered Loop for 2-Wire Smoke Detectors

11.1 Terminals 12 and 13

A resettable 2-wire Class B powered loop is provided on terminals 12 (positive) and 13 (negative) of the panel. For programming purposes the loop number is 5. The loop uses a Model 309, 3.3K Ω EOL resistor provided with the panel and has an operating range of 8.8 to 14.2 VDC. The UL compatibility identifier is: A. The following detectors are compatible with the 1912XR and 715 Loop Expander powered loops:

Mfg	Model	Detector I D	Base	Base I D	# of Detectors
SS	1151	A	B110LP or B116LP	—	10
SS	2151	A	B110LP or B116LP	—	10
SS	1400	A	—	—	12
SS	1451	A	B401 or B401B	A	10
SS	1451DH	A	DH400	A	10
SS	2400, 2400TH	A	—	—	10
SS	2451, 2451TH	A	B401 or B401B	A	10
SS	2451	A	DH400	A	10
DS	DS200/DS200HD	A	MB200-2W	A	15
DS	DS250/DS250TH	B	MB2W/MB2WL	A	10
ESL	422C/422CT	S10P	—	—	25
ESL	429C/429CT	S09A	—	—	12
ESL	422CRT/422CST	S11A	—	—	12
HOC	SLK-12	HD-4	HSB - 12 - 1	HB-80	18

RA-400 MAY BE USED ON ALL BRK DETECTORS
USE 330 OHM RESISTOR IN MB200-2W BASE
DIFFERENT DETECTOR MODELS MAY NOT BE MIXED

Figure 6: Compatible 2-wire smoke detectors

Protection Loops

12.1 Description

Terminals 14 to 19 are the four burglary loops. For programming purposes, the loop numbers are 1 to 4. Terminals 14 to 19 provide connection as described below.

Terminal	Function
14	Loop 1 voltage sensing
15	Ground for Loops 1 & 2
16	Loop 2 voltage sensing
17	Loop 3 voltage sensing
18	Ground for Loops 3 & 4
19	Loop 4 voltage sensing

The voltage sensing terminal measures the voltage flowing through a 1k Ω End Of Line resistor to ground.

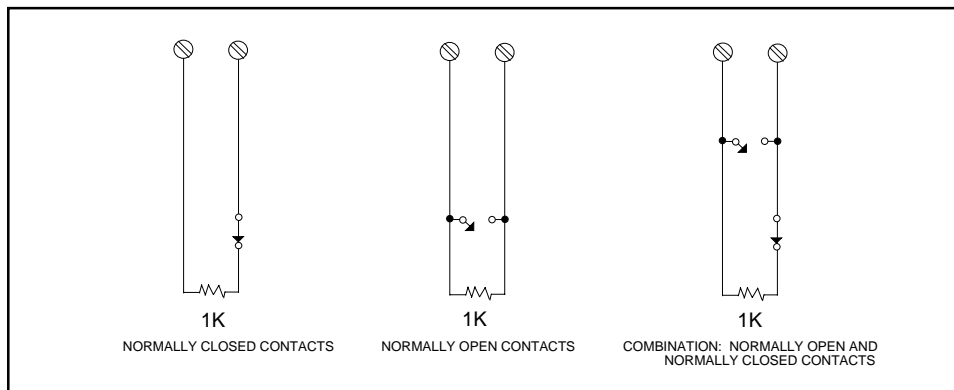

Figure 7: Protection loop contact wiring

Dry contact sensing devices can be used in series (normally-closed) or in parallel (normally-open) with any of the burglary protection loops.

12.2 Operational parameters

Each burglary protection loop detects three conditions: open, normal, and short. The parameters for each are listed below:

Condition	Resistance on loop	Voltage on right terminal
Open	over 1300 ohms	over 2.0 VDC
Normal	600 to 1300 ohms	1.2 to 2.0 VDC
Short	under 600 ohms	under 1.2 VDC

12.3 Loop response time

A condition must be present on a loop for 500 milliseconds (1/2 second) before it's detected by the 1912XR panel. Make sure any detection devices you use on the protection loops are rated for use with this delay. Loops can also be programmed for a Fast Response delay of 160 milliseconds.

12.4 Keyswitch arming loop (maintained)

Programming a loop as an Arming Type, allows selected areas to arm when the loop is placed into a short condition. The selected areas disarm when the loop is placed into a normal (1K Ω EOL) condition. If placed into an open condition from a normal (disarmed) condition, a trouble is reported. If placed into an open condition from a short (armed) condition, an alarm is reported and the loop is disabled until another disarming occurs within the system. The areas controlled by the loop and the relay outputs that indicate their armed or disarmed status are selected in the panel's Programmer.

Dry Contact Relay Outputs

13.1 Description

Two Form C (SPDT) relay outputs can be provided on the 1912XR by installing two DMP Model 305 relays into the sockets labeled K9 (Output 1) and K5 (Output 2). Both relays can be operated by the functions listed below:

- 1) Activation by loop condition
 - Steady
 - Pulsing
 - Momentary
 - Follow
- 2) Activation by 24 hour 7 day schedule
 - One on and one off time a day for each relay
- 3) Manually from the Security Command keypad User Menu
- 4) Communication failure output
- 5) Armed area annunciation
- 6) Fire Alarm or Fire Trouble
- 7) Other system conditions. See the 1912XR Programming Manual (LT-0171).

13.2 Contact rating

The DMP 1912XR relay contacts are rated for 1 Amp at 30 VDC or 0.5 Amp at 120 VAC. The auxiliary output power from terminal 7 can be internally connected to the common terminal of Relay Output 1 by installing the J15 jumper across both pins.

13.3 Harness wiring

The relay contacts are accessible by installing the DMP 304 Harness on the 10-pin header labeled J2. The contact locations are shown below:

Contact	Color	Wire
Output 1 normally closed	Violet	10
Output 1 common	Gray	9
Output 1 normally open	Orange	8
Output 2 normally closed	Violet	7
Output 2 common	Gray	6
Output 2 normally open	Orange	5

The relay contacts must be connected to devices located within the same room as the 1912XR panel.

12 VDC Outputs 3 to 6

14.1 Description

Four 12 VDC, 50mA voltage outputs are provided on the panel's J2 Output Harness to power external relay coils or other low power indicators. The voltage outputs can be operated by all of the same functions as Relay Outputs 1 and 2.

When connecting any devices to outputs 3 to 6, subtract the current draw of the device from the panel's available auxiliary power.

14.2 Harness wiring

To use the voltage outputs on the panel, install a DMP 304 Harness (available separately) onto the 10-pin header labeled J2. The wire harness descriptions are shown below:

Output	Color	Harness Wire
3	White/Brown	4
4	White/Red	3
5	White/Orange	2
6	White/Yellow	1

Devices connected to the outputs must be located within the same room as the 1912XR panel.

Telephone RJ Connector

15.1 Description

Connect the panel to the public telephone network by installing a DMP 356 RJ Cable between the panel's J3 connector and the RJ31X or RJ38X phone jack. Set the 3-pin headers labeled J11 and J12 on the 1912XR to DD for dialer or DDMX operation or MPX for multiplex operation.

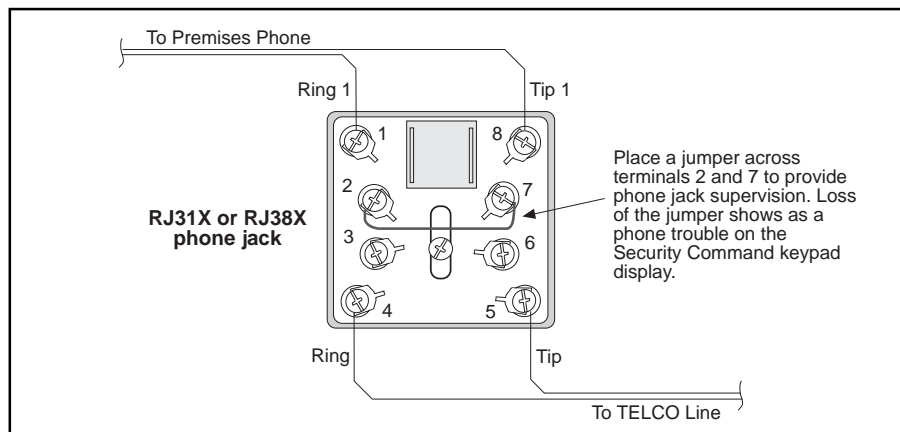

Figure 8: Phone jack wiring

15.2 FCC registration

The Model 1912XR complies with FCC part 68 and is registered with the FCC. Registration number: CCKUSA-18660-AL-R Ringer Equivalence: 1.3B

15.3 Notification

Registered terminal equipment must not be repaired by the user. In case of trouble, the device must be immediately unplugged from the telephone jack. The factory warranty provides for repairs. Registered terminal equipment may not be used on party lines or in connection with coin telephones. Notification must be given to the telephone company of:

- a. The particular line(s) the service is connected to
- b. The FCC registration number
- c. The ringer equivalence
- d. The make, model, and serial number of the device

15.4 Ground start

For ground start operation, install the DMP 305 Relay into socket K2.

Reset Jumper J16

16.1 Description

The reset jumper is located just above the terminal strip in the center of the circuit board and is used to reset the microprocessor of the 1912XR. To reset the panel when first installing the system, install the reset jumper before applying power to the panel. After connecting the AC and battery, remove the reset jumper.

To reset the panel while the system is operational (for example, prior to reprogramming), install the reset jumper without powering down the system. Remove the reset jumper after two seconds.

After resetting the panel for programming, you must begin within 30 minutes. If you wait longer than 30 minutes, you'll have to reset the panel again.

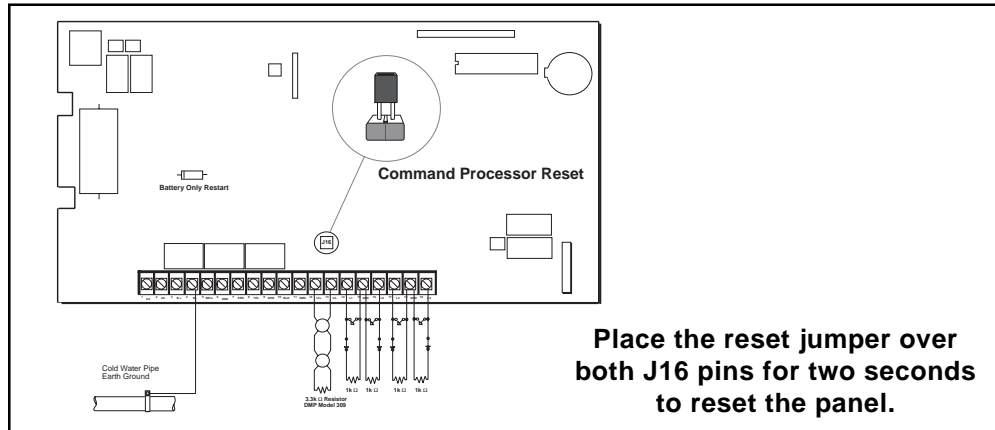

Figure 9: 1912XR panel showing reset

16.2 Tamper connector J4

Jumper J4 is used for connecting the DMP 306 tamper kit when required for multiplex or Grade A operation.

UNIVERSAL UL BURGLARY SPECIFICATIONS

17.1 Introduction

The programming and installation specifications contained in this section must be completed when installing the 1912XR panel in accordance with any of the UL burglary standards. Additional specifications may be required by a particular standard.

17.2 Wiring

All wiring must be in accordance with NEC, ANSI/NFPA 70, UL 681, and UL 611 for all burglary installations.

17.3 Control outside of protected area

A Potter EVD or Sentrol 5402 should be used in place of a lined cabinet when the panel is installed outside of the protected area.

17.4 Police station phone numbers

The digital dialer telephone number programmed for communication must not be a police station phone number, unless that phone number is specifically provided for that purpose.

17.5 Bypass reports

The bypass reports option must be programmed as YES for all UL burglary applications. See section 6.3 of the 1912XR Programming Manual (LT-0171).

17.6 System maintenance

Proper installation and regular maintenance by the installing alarm company and frequent testing by the end user is essential to ensure continuous satisfactory operation of any alarm system. Offering a maintenance program and acquainting the user with the correct procedure for use and testing of the system is also the responsibility of the installing alarm company.

17.7 Partitions

The partition option may only be used for UL burglary applications when all partitions are used for one subscriber. See section 4.2 and 11.2 of the 1912XR Programming Manual (LT-0171). The panel must be tamper protected and Sentrol Model 5402 or Potter EVD listed vibration detectors should be used.

17.8 Cross zoning

Loops used for cross zoning must be installed to allow detection of the same event. For example, two motion detectors in the same hallway.

UL 1023 SPECIFICATIONS

Household Burglar-Alarm System Units

18.1 Bell cutoff

The bell cutoff time cannot be less than five minutes. See section 8.2 of the 1912XR Programming Manual (LT-0171).

18.2 Entry delay

The maximum entry delay used must not be more than 45 seconds. See section 7.3 of the 1912XR Programming Manual (LT-0171).

18.3 Exit delay

The maximum exit delay used must not be more than 60 seconds. See section 11.4 of the 1912XR Programming Manual (LT-0171).

18.4 Weekly test

The product should be tested weekly.

UL 1610 and 1076 SPECIFICATIONS

Central-Station and Proprietary Burglar-Alarm Units

19.1 Multiplex network capacity

The total number of panels assigned to a standard MPX or DNET receiving line of the SCS-1 Receiver System must not exceed 90. This may be increased to 180 by setting the SNRM option to NO in the SCS-1 Receiver system. This is to allow any signal from a 1912XR Command Processor to be transmitted to the receiver within 90 seconds. This allows Grade AA Multiplex service.

19.2 Opening/Closing reports

The Opening/Closing Reports option must be programmed as YES. See section 11.6 of the 1912XR Programming Manual (LT-0171).

19.3 Closing wait

The Closing Wait option must be programmed as YES. See section 7.2 of the 1912XR Programming Manual (LT-0171).

19.4 Proprietary dialer

The Model 1912XR provides Grade A proprietary service when configured as a digital dialer.

19.5 DDMX operation

When DDMX communication is used, Grade B Central Station service is provided. See section 20.7 below and section 3.2 of the 1912XR Programming Manual (LT-0171).

19.6 AA Network Communication

When HST communication is used, a dialer line must also be used along with the Model 893 Dual Phone Line Module to supervise the dialer line. The HST Checkin time must be set from 01 to 06 minutes or AA. This provides AA Central Station Service. See sections 3.2, 3.2.1, and 3.3 of the 1912XR Programming Manual (LT-0171).

UL 1635 SPECIFICATIONS

Digital Burglar Alarm Communicator System Units

20.1 System trouble display

The Status List Display must include at least one keypad that displays system monitor troubles. See section 10.1 of the 1912XR Programming Manual (LT-0171).

20.2 Digital Dialer telephone number

Both programmed telephone numbers must begin with a D or P. See sections 3.17 and 3.18 of the 1912XR Programming Manual (LT-0171).

20.3 Entry delay

The maximum entry delay used must not be more than 60 seconds. See section 7.3 of the 1912XR Programming Manual (LT-0171).

20.4 Exit delay

The maximum exit delay used must not be more than 60 seconds. See section 11.4 of the 1912XR Programming Manual (LT-0171).

20.5 Test time

The Test Time option must be programmed so that the 1912XR sends a report once every 24 hours. See sections 3.8 to 3.10 of the 1912XR Programming Manual (LT-0171).

20.6 Closing wait

The Closing Wait option must be programmed as YES. See section 7.2 of the 1912XR Programming Manual (LT-0171).

20.7 Grade B Central Station

Grade B Central Station service can be provided under UL 1635 by adding a Grade A local audible signal appliance and placing the Model 1912XR panel into the Model 349A Grade A Attack Resistant Housing.

UL 365 and 609 SPECIFICATIONS

Police Station Connected and Local Burglar Alarm Units and Systems

21.1 System trouble display

The Status List Display must include at least one keypad that displays system monitor troubles. See section 10.3 of the 1912XR Programming Manual (LT-0171).

21.2 Entry delay

The maximum entry delay used must not be more than 60 seconds when using the Model 349A Grade A housing. See section 7.3 of the 1912XR Programming Manual (LT-0171).

21.3 Grade A bell

A Grade A local audible signal appliance must be used.

21.4 Bell cutoff

The bell cutoff time cannot be less than 15 minutes. See section 8.2 of the 1912XR Programming Manual (LT-0171).

21.5 Automatic bell test

The Automatic Bell Test option must be programmed as YES. See section 8.3 of the 1912XR Programming Manual (LT-0171).

21.6 Grade A Mercantile

For Grade A Mercantile and Police Station Connect operation the Model 1912XR must be mounted in a Grade A attack resistant housing, (DMP Model 349A).

21.7 Mercantile Safe and Vault

When the DMP Model 349A housing is used, the 1912XR provides operation as a mercantile safe and vault alarm. Bell Supervision and wiring must be in accordance with UL 681. If the Model 1912XR is mounted outside the safe or vault, tamper protection and the Sentrol Model 5402 or Potter EVD listed vibration detectors should be used.

21.8 Basic Line security for Police Connect

Basic line security is provided when the Model 1912XR is configured as a dialer system.

21.9 Transformer

A 40VA transformer must be used. Use the DMP Model 320 or 321.

21.10 Bank Safe and Vault

The Bank Safe and Vault function has not been investigated by Underwriters Laboratories. See section 11.19 of the 1912XR Programming Manual (LT-0171).

21.11 High Line Security

High line security is provided when configured as a MPX, DNET, or HST system. When HST communication is used, a dialer line must also be used along with the Model 893 Dual Phone Line Module to supervise the dialer line. The HST Checkin time must be set from 01 to 06 minutes or AA. See sections 3.2, 3.2.1, and 3.3 of the 1912XR Programming Manual (LT-0171).

UNIVERSAL UL and NFPA FIRE ALARM SPECIFICATIONS

22.1 Introduction

The programming and installation specifications contained in this section must be completed when installing the Model 1912XR in accordance with any of the UL or NFPA fire standards. Additional specifications may be required by a particular standard.

22.2 Wiring

All wiring must be in accordance with NEC, ANSI/NFPA 70.

22.3 Transformer

A wire-in transformer should be used. Use the 16.5 VAC Model 320 at 40VA or Model 322 at 100VA.

22.4 End of Line resistor

The DMP Model 310 1K Ω EOL resistor should be used on all 1K Ω EOL fire loops.

22.5 System trouble display

The Status List Display must include at least one keypad that displays system monitor troubles. See section 10.3 of the 1912XR Programming Manual (LT-0171).

22.6 Fire display

The Status List Display must include at least one keypad that displays troubles and alarms on fire type loops. See section 10.4 of the 1912XR Programming Manual (LT-0171).

22.7 Police station phone number

The digital dialer telephone number programmed for communication must not be a police station phone number, unless that phone number is specifically provided for that purpose.

22.8 System maintenance

Proper installation and regular maintenance by the installing alarm company and frequent testing by the end user is essential to ensure continuous satisfactory operation of any alarm system. Offering a maintenance program and acquainting the user with the correct procedure for use and testing of the system is also the responsibility of the installing alarm company.

22.9 Audible alarm

Fire Type loops should be programmed to activate an audible alarm. The Bell Action for Fire Type loops should not be programmed as "N". See section 8.4A in the 1912XR Programming Manual (LT-0171).

22.10 Fire loop programming

Fire loops must be programmed to activate a trouble on open conditions and an alarm on short conditions. The swinger bypass function must not be used on any fire loops. If a retard is used on a waterflow loop it cannot exceed 60 seconds and any retard in the waterflow initiating devices must be subtracted from the 60 seconds allowed. See sections 12.7 and 12.17 in the 1912XR Programming Manual (LT-0171). The retard delay should not be used on a loop with smoke detectors.

22.11 Model 774 keypad

The fire key in the upper right corner of the 774 keypad is not intended to replace a manual pull station.

22.12 Style D loops

If required, the Radionics D129 Dual Style D Initiating Module provides for connection of two Style D loops to the Model 1912XR. See section 26.4 and the D129 Installation Instructions for wiring information.

22.13 Video option

The video option must be selected as NO when any fire protection is connected to the 1912XR. See section 7.9 in the 1912XR Programming Manual (LT-0171).

UL 985 NFPA 74 SPECIFICATIONS Household Fire Warning System Units

23.1 Bell output definition

The bell output of the Model 1912XR must be programmed to operate steady on burglary alarms and pulsed on fire alarms. See sections 8.4A and 8.4B of the 1912XR Programming Manual (LT-0171).

UL 864 NFPA 71 – 72 (Chapter 9) SPECIFICATIONS Control Units for Fire-Protective Signaling Systems

24.1 Loop restoral reports

The Restoral Reports option must be selected as YES or DISARM. See section 12.11 in the 1912XR Programming Manual (LT-0171).

24.2 Power fail delay

The Power Fail Delay option must be selected as 6 hours. See section 7.6 of the 1912XR Programming Manual (LT-0171).

24.3 Sprinkler supervisory

Any loop used for sprinkler supervisory must be programmed with "SPRINKLRXX" as the loop name. The last two characters in the loop name may be assigned a number to identify the loop number.

24.4 DACT systems

Two phone lines must be used. The two phone lines cannot be ground start or party lines. The 893 Dual Phone Line Module is used to provide connection of two phone lines to the system. The backup communication option must be selected as YES.

Two different phone numbers must be programmed for digital communication. See sections 3.17 and 3.18 of the 1912XR Programming Manual (LT-0171). The test time option must be programmed so that the 1912XR sends a report every 24 hours. See sections 3.8 to 3.10 of the 1912XR Programming Manual.

Additionally, you can use the 862N Network Interface Card and the HST (Host) Communication type for ancillary communication over digital data networks.

24.5 Type 2 and Type 3 Central Station Service

Type 2 and Type 3 Central Station service can be provided by using multiplex communication to the DMP SCS-1 Receiver system. The 1912XR should be set to MPX communication. See section 15.1 of this manual and section 3.2 of the 1912XR Programming Manual (LT-0171).

24.6 Type 1 Central Station Service

Type 1 Central Station service can be provided by using multiplex as the main communication and digital dialer as backup. The 893 Dual Phone Line Module is used to provide connection of the multiplex and dialer lines. See section 3.2 of the 1912XR Programming Manual (LT-0171). If Type 1 Central Station service is provided, the test time option must be programmed to send a report every 24 hours. See sections 3.8 to 3.10 of the 1912XR Programming Manual.

With both Type 1 and Type 2 Central Station service, the total number of control panels assigned to a standard MPX receiving line of the SCS-1 Receiver System must not exceed 90. This may be increased to 180 by setting the SNRM option to NO in the SCS-1 Receiver system. This is to allow any signal from a 1912XR to be transmitted to the receiver within 90 seconds.

24.7 Keypad 4-wire bus

The keypad and loop expander 4-wire bus must be run entirely in conduit and remain inside the same room as the panel, unless an external communication fail indicator is added. A 12 VDC relay may be wired as a communication failed indicator. Connect the positive side of the indicator to one of the voltage outputs and the negative side to keypad ground (terminal 10) of the 1912XR. See section 14.2.

In addition to the wiring above, the device fail output must be programmed to activate the appropriate voltage output. See Section 8.5L of the 1912XR Programming Manual (LT-0171).

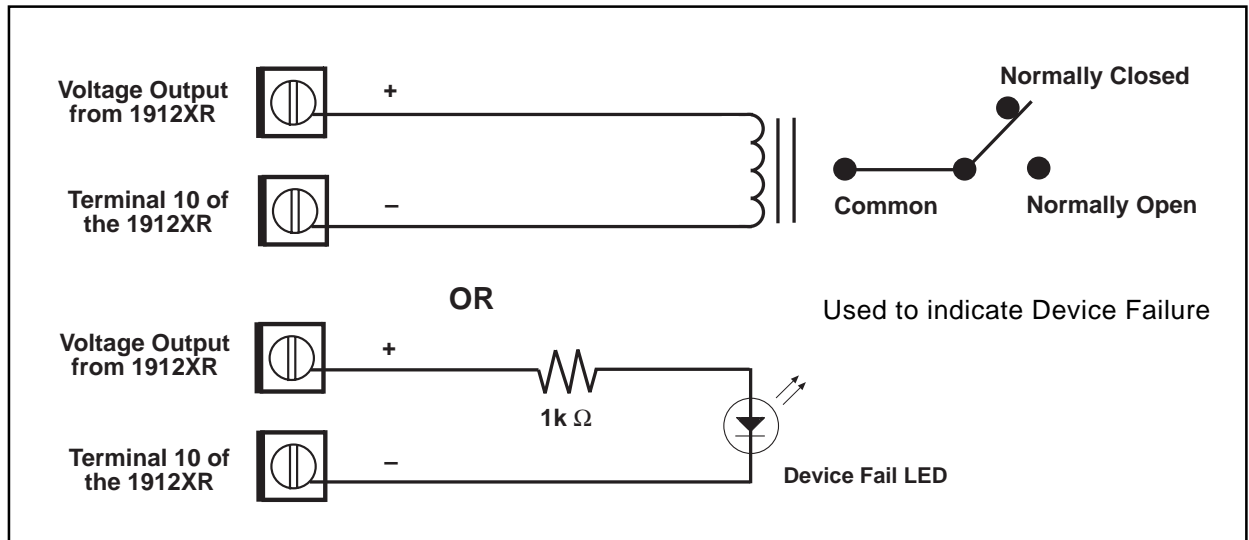

Figure 10: Device fail output configuration

24.8 Local Protective Signaling Systems

The DMP Model 866 Indicating Circuit Module must be used on the bell circuit for detection of shorts and grounds. See sections 26.1 to 26.3 for wiring diagrams. An alphanumeric keypad must be used for local systems.

24.9 Proprietary Protective Signaling Systems

The total number of panels assigned to one multiplex receiving line of the DMP SCS-1 Receiver system must not exceed 90. This may be increased to 180 by setting the SNRM option to NO in the SCS-1 Receiver system. This is to allow any report from a 1912XR to be sent to the receiver within 90 seconds.

24.10 Remote Station Protective Signaling Systems

You must provide 60 hours of standby battery. Up to four 12 VDC, 6.5Ah batteries may be used along with a 16 VAC, 100VA transformer (DMP Model 322). See section 7.6 for standby battery calculations. Two Radionics Model D127 Reversing Relay Modules provide two reversing polarity telephone connections. See section 26.5 and the D127 Installation Instruction sheet for wiring details. A DMP Model 893 must be used to provide two line dialer communication or Type 1 Multiplex communication.

CALIFORNIA STATE FIRE MARSHAL SPECIFICATIONS

25.1 Bell output definition

The bell output of the Model 1912XR must be programmed to operate steady on burglary alarms and pulsed on fire alarms. See sections 8.4A and 8.4B of the 1912XR Programming Manual (LT-0171).

26.1 Indicating circuit module installation

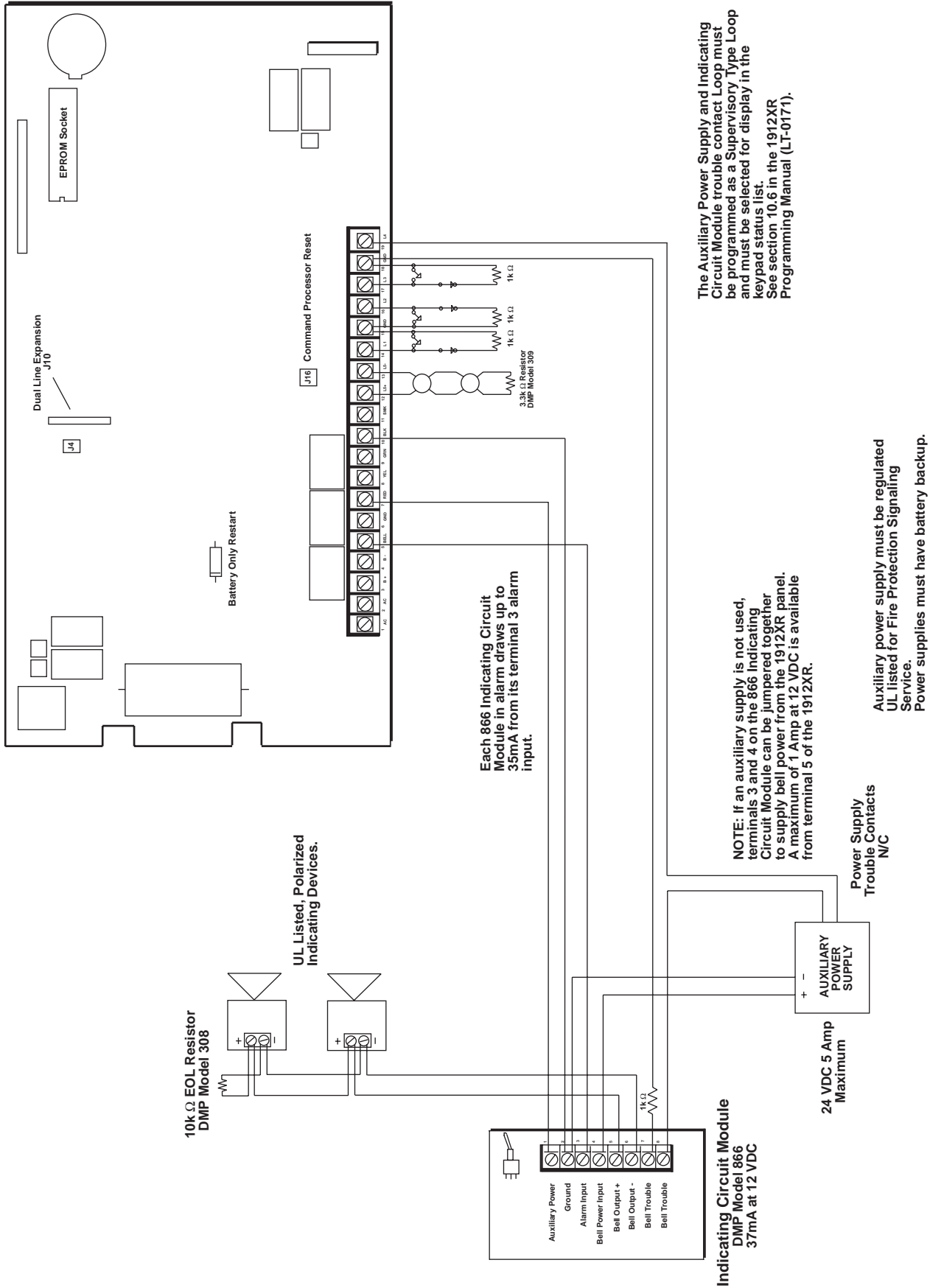

26.2 Multiple Indicating circuit modules

To additional fourteen 866 Indicating Circuit Modules. Up to a maximum of sixteen 866 modules on the 1912XR panel. All modules must be installed in a listed enclosure connected by conduit and located in the same room.

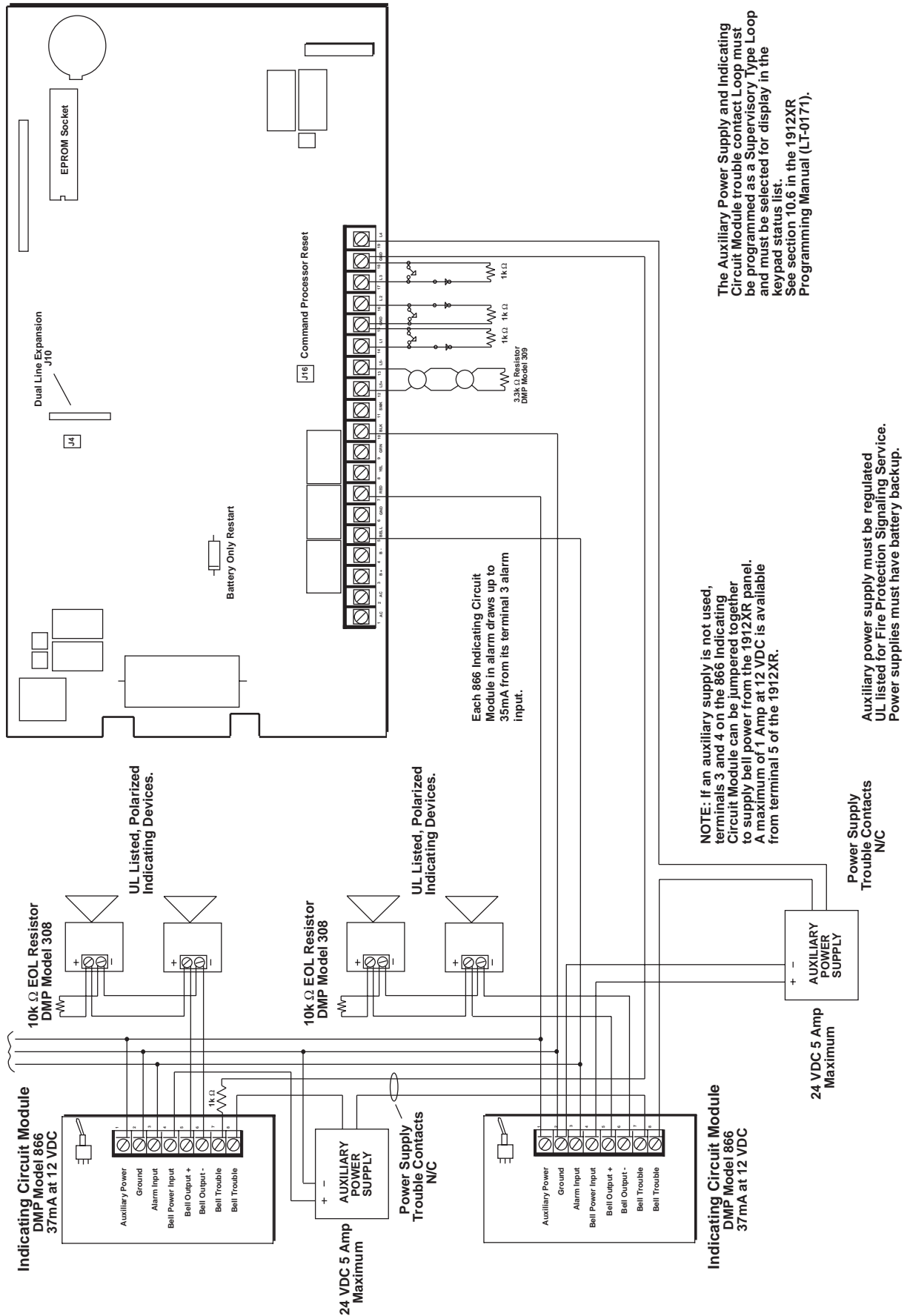

NOTE: If an auxiliary supply is not used, terminals 3 and 4 on the 866 Indicating Circuit Module can be jumpered together to supply bell power from the 1912XR panel. A maximum of 1 Amp at 12 VDC is available from terminal 5 of the 1912XR.

The Auxiliary Power Supply and Indicating Circuit Module trouble contact Loop must be programmed as a Supervisory Type Loop and must be selected for display in the keypad status list. See section 10.6 in the 1912XR Programming Manual (LT-0171).

Auxiliary power supply must be regulated UL listed for Fire Protection Signaling Service. Power supplies must have battery backup.

26.3 Multiple Indicating circuit modules for zoned annunciation

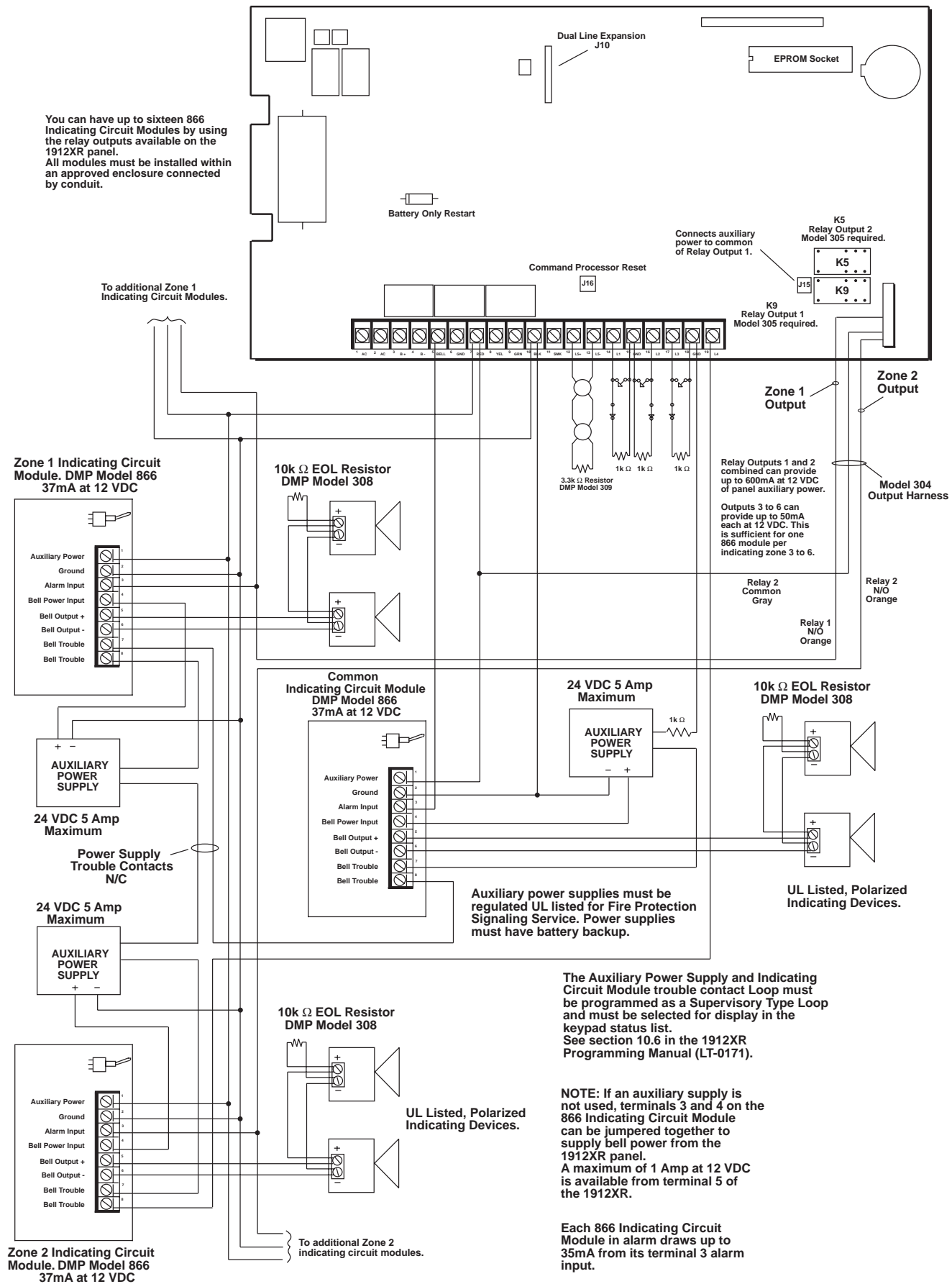

26.4 Dual Style D Loop module installation

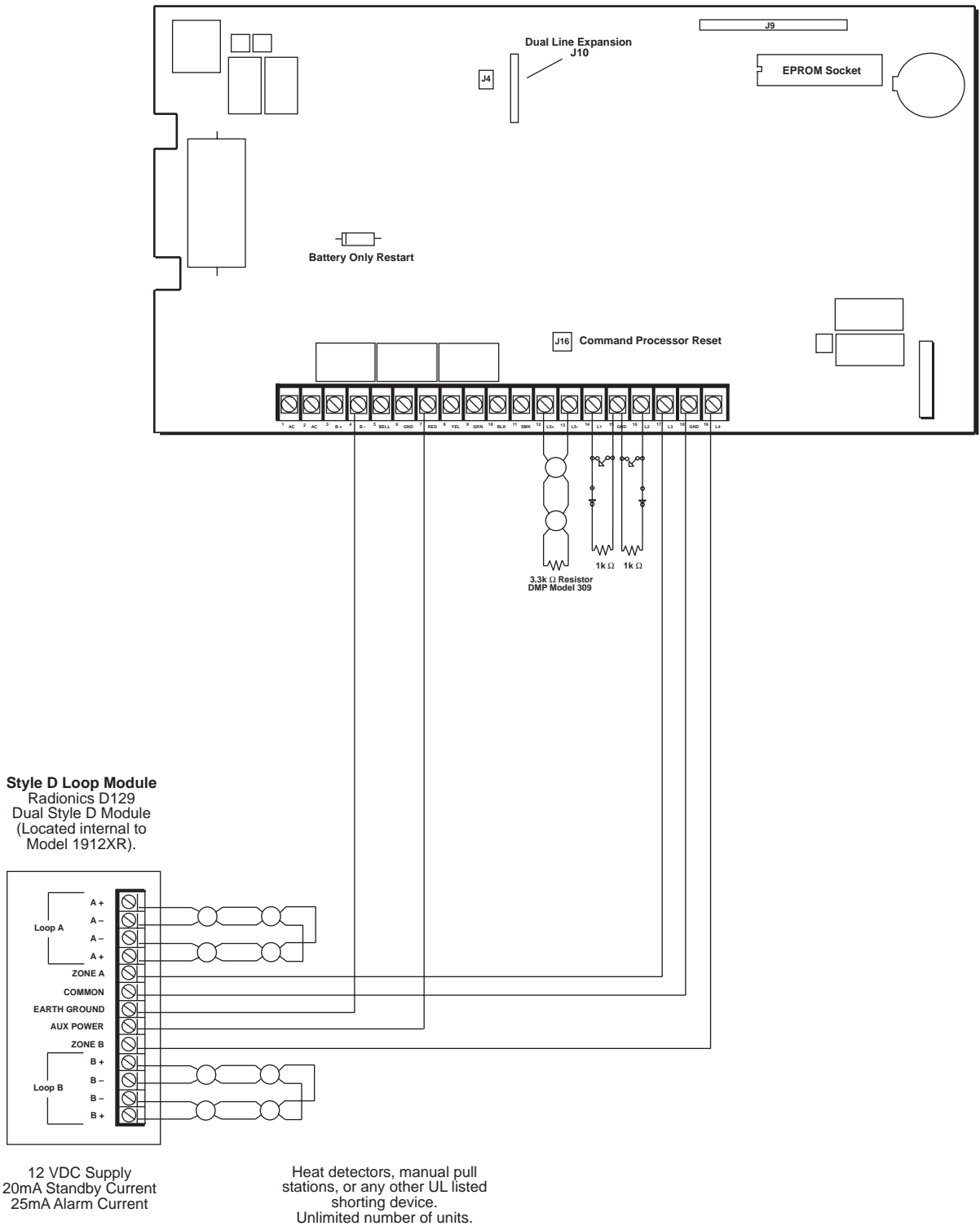

26.5 Remote Station

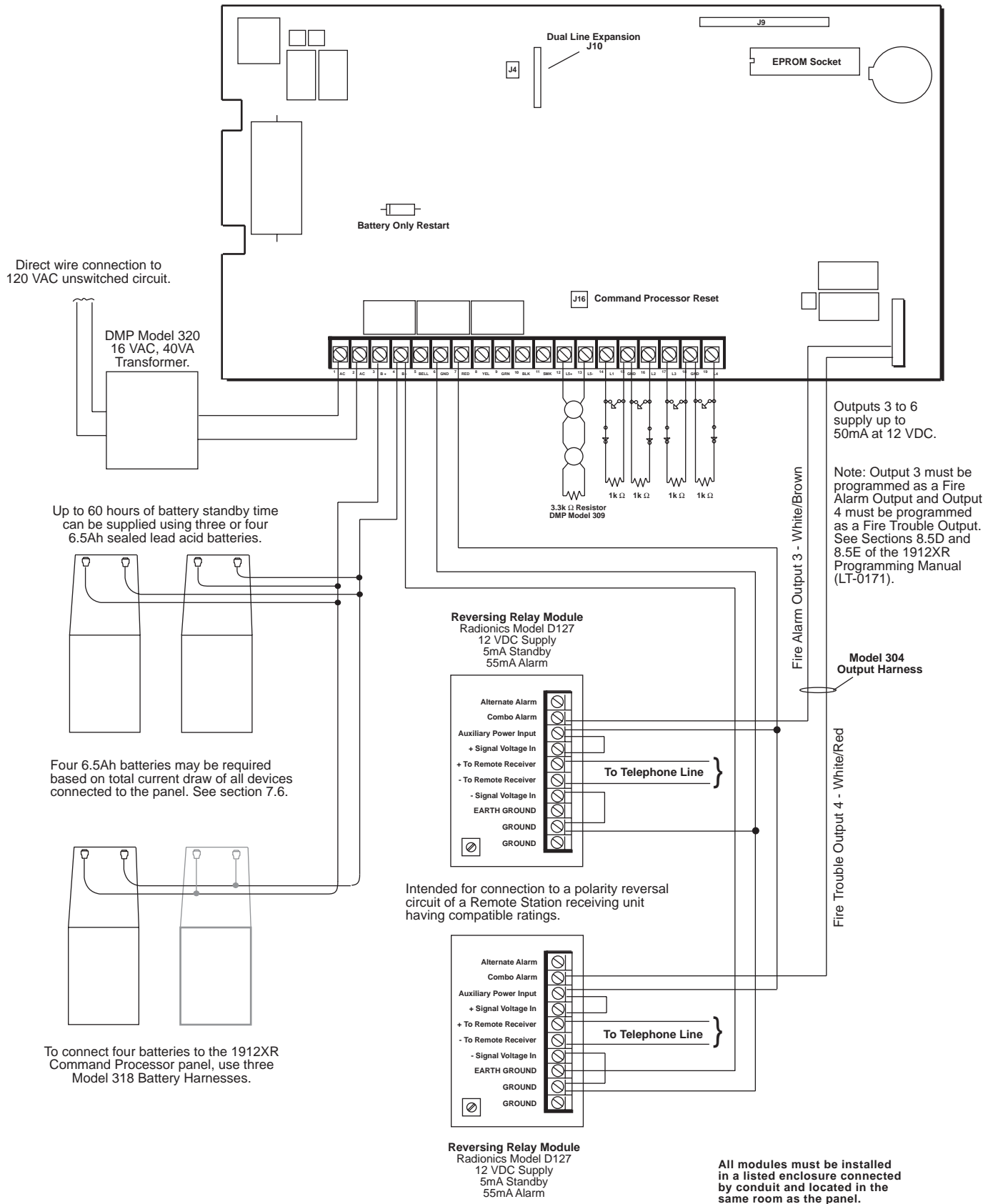

Direct wire connection to 120 VAC unswitched circuit.

DMP Model 320
16 VAC, 40VA
Transformer.

Up to 60 hours of battery standby time can be supplied using three or four 6.5Ah sealed lead acid batteries.

Four 6.5Ah batteries may be required based on total current draw of all devices connected to the panel. See section 7.6.

To connect four batteries to the 1912XR Command Processor panel, use three Model 318 Battery Harnesses.

Outputs 3 to 6 supply up to 50mA at 12 VDC.

Note: Output 3 must be programmed as a Fire Alarm Output and Output 4 must be programmed as a Fire Trouble Output. See Sections 8.5D and 8.5E of the 1912XR Programming Manual (LT-0171).

Reversing Relay Module
Radionics Model D127
12 VDC Supply
5mA Standby
55mA Alarm

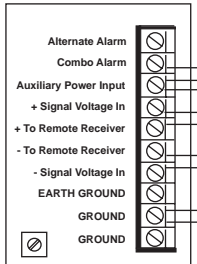

Intended for connection to a polarity reversal circuit of a Remote Station receiving unit having compatible ratings.

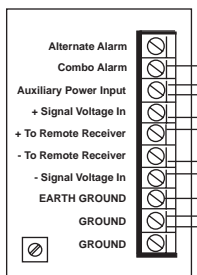

Reversing Relay Module
Radionics Model D127
12 VDC Supply
5mA Standby
55mA Alarm

All modules must be installed in a listed enclosure connected by conduit and located in the same room as the panel.

26.6 Supervised Remote Relay

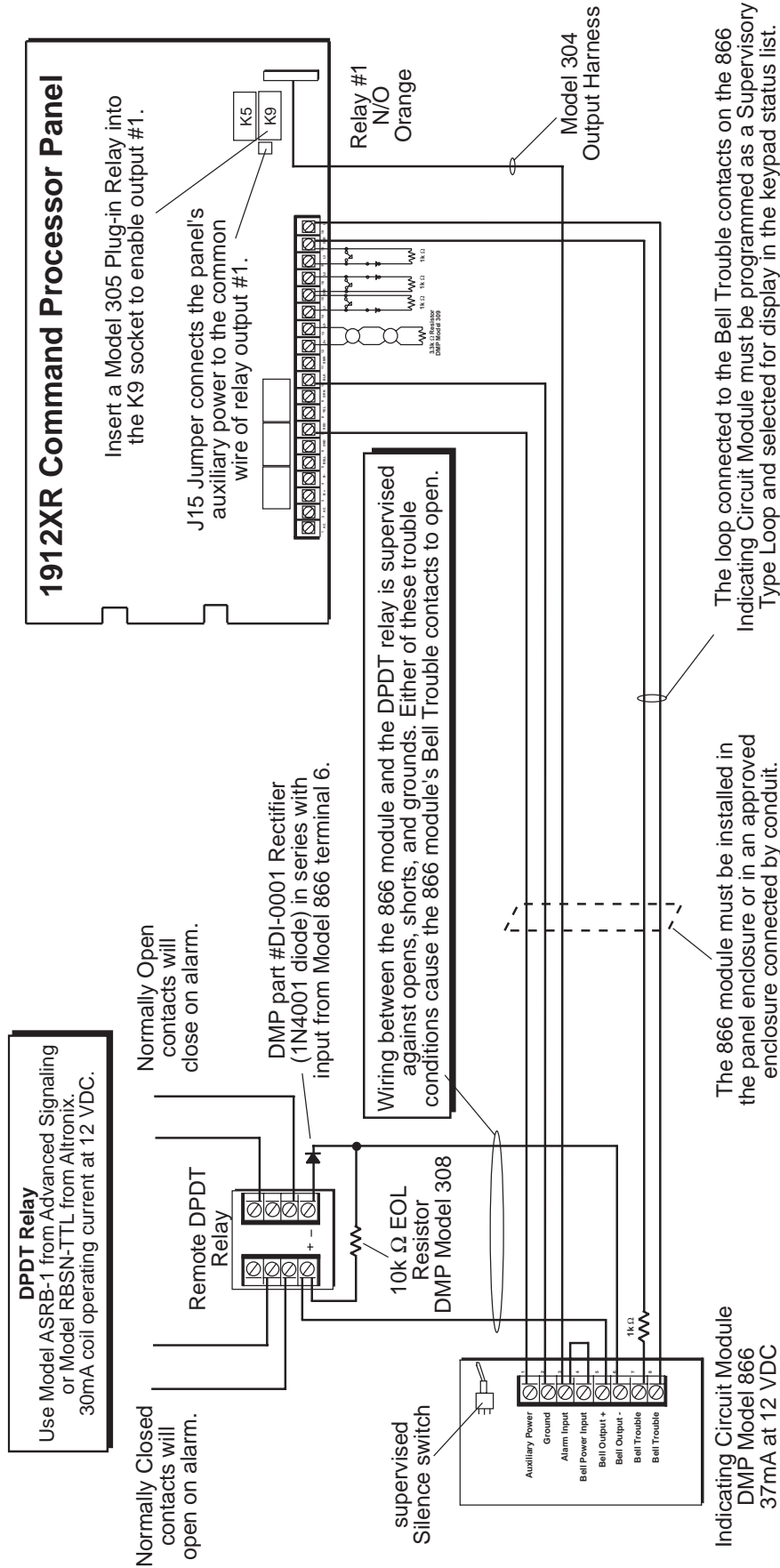

26.7 Cellular backup installation

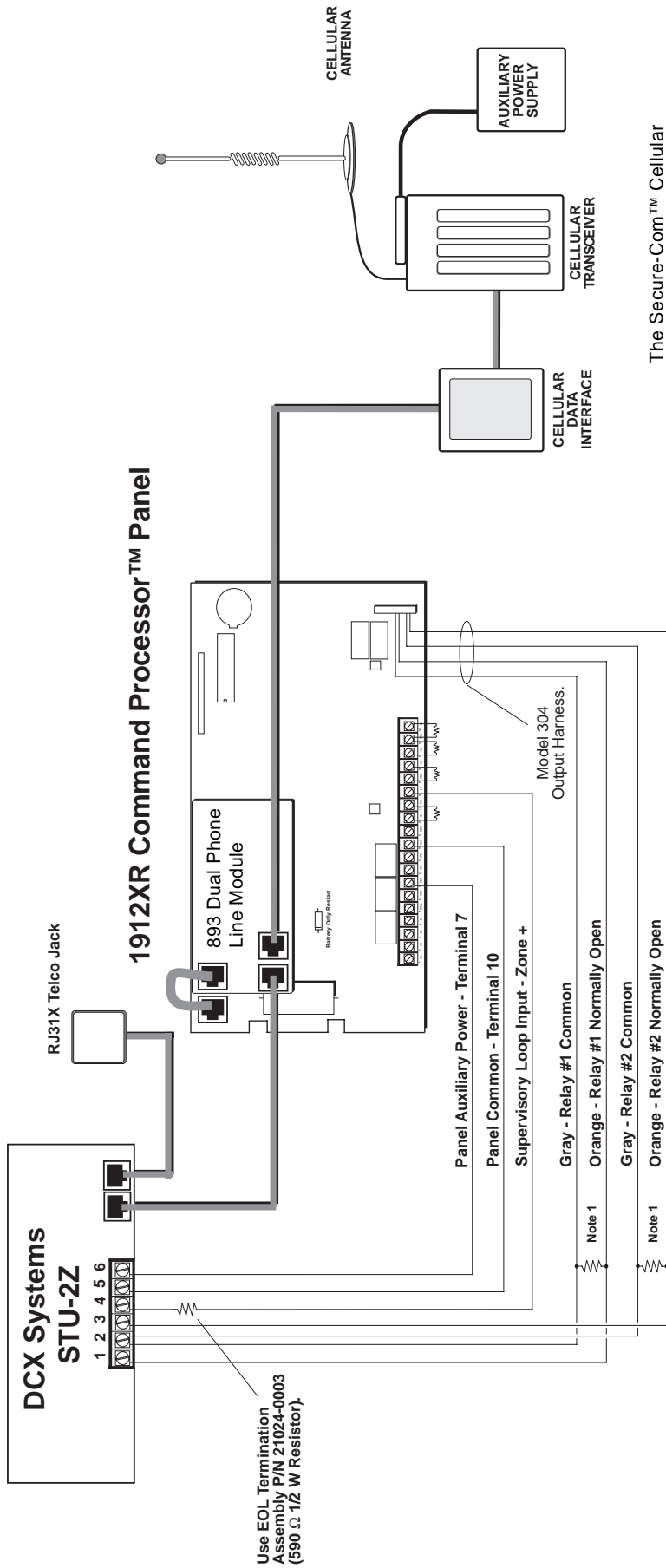

Use EOL Termination Assembly P/N 21024-0003 (590 Ω 1/2 W Resistor).

The Secure-Com™ Cellular System must be connected to a separate power supply.

Note 1: Use EOL Termination Assembly P/N 21024-0001 (2.2k 1/2 W Resistor).

Troubleshooting Section

27.1 Description

This section of the 1912XR Installation Guide provides troubleshooting information for use when installing or servicing a 1912XR system.

Problem	Possible Cause	Solution
Security Command keypads display " SERVICE REQUIRED"	J16 reset jumper is installed. Open or short on the green data wire to the keypad. Bad keypad or loop expander.	Remove the J16 reset jumper. Check for broken or shorted wires between the keypad and panel. Replace with a new or repaired keypad or loop expander.
Keypad display is not functional. When a key is pressed, only a short beep is emitted.	Open or short condition on the yellow data wire. Bad keypad or loop expander.	Check for broken or shorted wires. Replace with a new or repaired keypad or loop expander.
Loop Expander loops show open at the keypad. The Data LED on a loop expander does not flicker.	Open condition on the data wires. Panel powered down or a power supply connected to the loop expander is powered down. Bad loop expander. Loops are not programmed.	Check for broken wires. Apply AC power to the panel or loop expander. Replace with a new or repaired loop expander. Use the Setup LPX function.
Bell or siren connected to the panel rings continuously.	The capacitor on the panel's output is not discharging.	Install a 1k Ω resistor across the bell output at the panel.
Keypad beeps when keys are pressed but won't allow the user to arm or enter the User Menu.	Two or more keypads are assigned to the same address.	Set each keypad to a different address to match the Device Setup programming.
Keypad displays "CLOSING TIME!" or "area name - LATE" and buzzes every hour.	Closing Check in the programming is set to YES and there are no schedules programmed.	Turn Closing Check to NO or enter schedule times through the keypad User Menu.
Panel won't dial.	Transmission jumpers missing or on wrong pins. Transmission type programmed as NONE. Receiver reports programmed NO.	Set both jumpers on DD pins. Program correct transmission type. Program one or more receiver reports as YES.
Keypad displays PHONE LINE 1 TROUBLE.	No jumper installed on phone jack terminals 2 and 7.	Install a jumper across terminals 2 and 7 on the phone jack.

Troubleshooting Section continued

Problem	Possible Cause	Solution
Loops on an expansion card data bus will not set.	Too much line noise. Too long of a wire run to devices. Too small a wire size or insufficient auxiliary power.	Move wires away from RF sources. Relocate panel closer to devices. Replace with a larger wire size or add an auxiliary power supply.
LPX Setup shows overlapped, missing, or extra loops.	Loop expanders are incorrectly addressed. There are unused loops on one or more expanders.	Correct the address settings to match the panel's programming. Leave as is or assign loops to an area.
Thermal circuit breaker on panel pops on and off.	Too much current draw from terminals 7, 11, the output relays, and/or the data bus of an expansion card.	Reduce current draw to below the 600mA allowable. Install a UL listed power supply



*MODEL 1912XR
COMMAND PROCESSOR
BURGLARY/FIRE
CONTROL PANEL/COMMUNICATOR
INSTALLATION GUIDE*



MODEL 1912XR COMMAND PROCESSOR INSTALLATION GUIDE

FCC NOTICE

This equipment has been tested and found to comply with the limits for a Class A digital device, pursuant to Part 15 of the FCC Rules. These limits are designed to provide reasonable protection against harmful interference when the equipment generates, uses, and can radiate radio frequency energy and, if not installed and used in accordance with the instruction manual, may cause harmful interference to radio communications. Operation of this equipment in a residential area is likely to cause harmful interference in which case the user will be required to correct the interference at his own expense.

Copyright © 1993-1996 Digital Monitoring Products, Inc.

Information furnished by DMP is believed to be accurate and reliable.
This information is subject to change without notice.

TABLE OF CONTENTS

	Section
Panel Specifications	
Power supply	1.1
Communication	1.2
Panel loops	1.3
Keypad and expanders	1.4
Output contacts	1.5
Enclosure specifications	1.6
Introduction	
Description	2.1
Expansion loops	2.2
Partitions and areas	2.3
Central station communication	2.4
Before you begin	2.5
About this guide	2.6
How to use this guide	2.7
System Components	
Description	3.1
Wiring diagram	3.2
Lightning protection	3.3
Accessory Devices	
Loop and output modules and interface cards	4.1
Indicating and initiating modules	4.2
893 Dual Phone Line Module	4.3
Security Command keypads	4.4
Installation	
Mounting the enclosure	5.1
Mounting keypads and loop expanders	5.2
Connecting serial devices	5.3
Primary Power Supply	
AC terminals 1 and 2	6.1
Transformer types	6.2
Secondary Power Supply	
Battery terminals 3 and 4	7.1
Earth ground	7.2
Battery only restart	7.3
Replacement period	7.4
Discharge/recharge	7.5
1912XR power requirements	7.6
Battery supervision	7.7
Battery cutoff	7.8
Bell Output	
Terminals 5 and 6	8.1
Keypad Data Bus	
Description	9.1
Terminal 7 - RED	9.2
Terminal 8 - YELLOW	9.3
Terminal 9 - GREEN	9.4
Terminal 10 - BLACK	9.5

TABLE OF CONTENTS

	Section
Smoke and Glassbreak Detector Output	
Terminal 11	10.1
Current rating	10.2
Powered Loop for 2-Wire Smoke Detectors	
Terminals 12 and 13	11.1
Protection Loops	
Description	12.1
Operational parameters	12.2
Loop response time	12.3
Keyswitch arming loop	12.4
Dry Contact Relay Outputs	
Description	13.1
Contact rating	13.2
Harness wiring	13.3
12 VDC Voltage Outputs 3 to 6	
Description	14.1
Harness wiring	14.2
Telephone RJ Connector	
Description	15.1
FCC registration	15.2
Notification	15.3
Ground start	15.4
Reset Jumper J16	
Description	16.1
Tamper connector J4	16.2
Universal UL Burglary Specifications	
Introduction	17.1
Wiring	17.2
Control outside of protected area	17.3
Police station phone numbers	17.4
Bypass reports	17.5
System maintenance	17.6
Partitions	17.7
Cross Zoning	17.8
UL 1023 Specifications	
Bell cutoff	18.1
Entry delay	18.2
Exit delay	18.3
Weekly test	18.4
UL 1610 and 1076 Specifications	
Multiplex network capacity	19.1
Opening/Closing reports	19.2
Closing wait	19.3
Proprietary dialer	19.4
DDMX operation	19.5

TABLE OF CONTENTS

Section

UL 1635 Specifications	
System trouble display	20.1
Digital dialer telephone number	20.2
Entry delay	20.3
Exit delay	20.4
Test time	20.5
Closing wait	20.6
Grade B Central Station	20.7
UL 365 and 609 Specifications	
System trouble display	21.1
Entry delay	21.2
Grade A bell	21.3
Bell cutoff	21.4
Automatic bell test	21.5
Grade A Mercantile	21.6
Mercantile Safe and Vault	21.7
Line security for Police Connect	21.8
Transformer	21.9
Bank Safe and Vault	21.10
Universal UL and NFPA Fire Alarm Specifications	
Introduction	22.1
Wiring	22.2
Transformer	22.3
End of Line resistor	22.4
System trouble display	22.5
Fire display	22.6
Police station phone number	22.7
System maintenance	22.8
Audible alarm	22.9
Fire loop programming	22.10
Model 774 keypad	22.11
Style D loops	22.12
UL 985 NFPA 74 Specifications	
Bell output definition	23.1
UL 864 NFPA 71 - 72 (Chapter 9) Specifications	
Loop restoral reports	24.1
Power fail delay	24.2
Sprinkler supervisory	24.3
DACT systems	24.4
Type 2 and Type 3 Central Station Service	24.5
Type 1 Central Station Service	24.6
Keypad 4-wire bus	24.7
Local Protective Signaling Systems	24.8
Proprietary Protective Signaling Systems	24.9
Remote Station Protective Signaling Systems	24.10

TABLE OF CONTENTS

Section

California State Fire Marshal Specifications

Bell output definition 25.1

Wiring Diagrams

Indicating circuit module installation 26.1

Multiple indicating circuit modules 26.2

Multiple indicating circuit modules for zoned annunciation 26.3

Dual Style D Loop Module installation 26.4

Remote Station 26.5

Supervised Remote Relay 26.6

Cellular backup installation 26.7

Troubleshooting Section

Description 27.1